

# IHI

Realize your dreams

## OIL-FREE TURBO COMPRESSORS

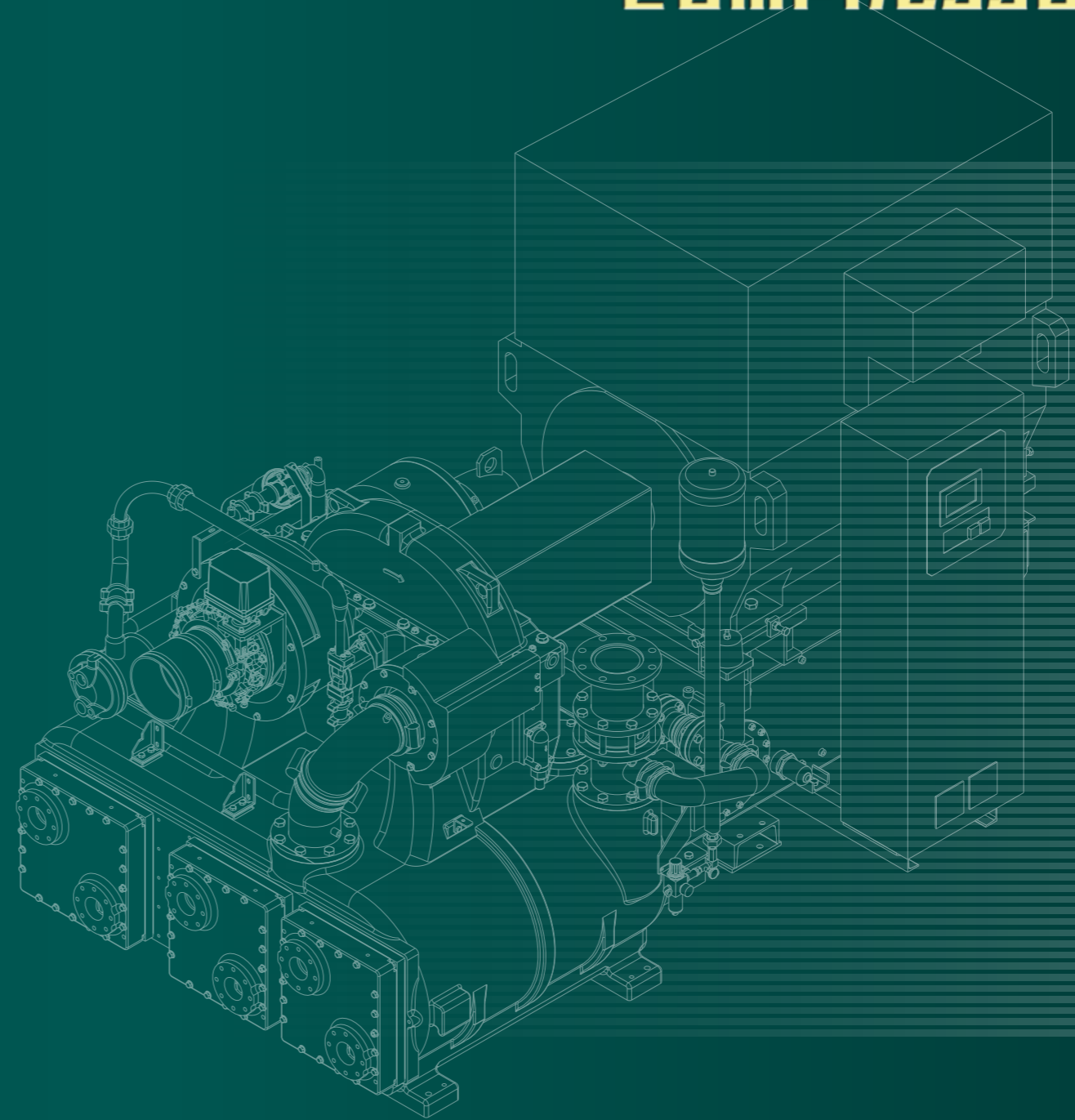

**Safety Precautions For your safety, be sure to read the user's manual before using.**

- Information contained in this catalog is that as of October, 2017.
- Note that specifications, dimensions and appearance contained in the catalog may be changed without notice for improvement.
- Note that the color tone of the product on the catalog may appear different from that of the actual product for reasons attributable to printing.
- Note that the addresses may be changed.
- TRA, TRE and TRX are trademark of IHI Corporation.

### IHI Rotating Machinery Engineering Co.,Ltd.

Sales Department  
Industrial Compressor Business Unit

7-12, Shinonome 1-chome, Koto-ku, Tokyo 135-0062 Japan  
Tel : +81-3-6703-0395 Fax : +81-3-6703-0398  
Website : <http://www.ihi.co.jp/compressor/en/>

1610-2000.GR Printed in Japan

**IHI Rotating Machinery Engineering Co.,Ltd.**

# Your Best Choice, IHI Turbo Compressors.

## IHI, making turbo compressor history

The history of IHI turbo compressors starts with a licence agreement in 1970. Since then, IHI has accumulated continuous technological innovation and built its own technologies, developing the whole product line-up from original designs. Further, in 1994, IHI succeeded in developing the world's smallest class of turbo compressor, the Tx series. In addition to strengthening the market value of compact turbo compressors, this product also enhanced the IHI product line-up. High performance and product quality can be seen in IHI's rich experience and proven track record. Our development concept is "Always looking ahead from a user perspective", and we are always trying to find benefit for our customers. There are over 7,000 IHI turbo compressors at work throughout the world today. IHI is continuing to make turbo compressor history.

## Energy-saving

World class efficiency achieved by utilizing our advanced rotating machinery technology. IHI turbo compressors bring high level energy saving to production operations, meeting today's stringent energy saving needs.

## User Customization

In the manufacturing workplace, compressed air needs are constantly changing. IHI matches optimal design to your production operation, in order to offer you the best choices.



Total numbers of IHI Turbo Compressors delivered

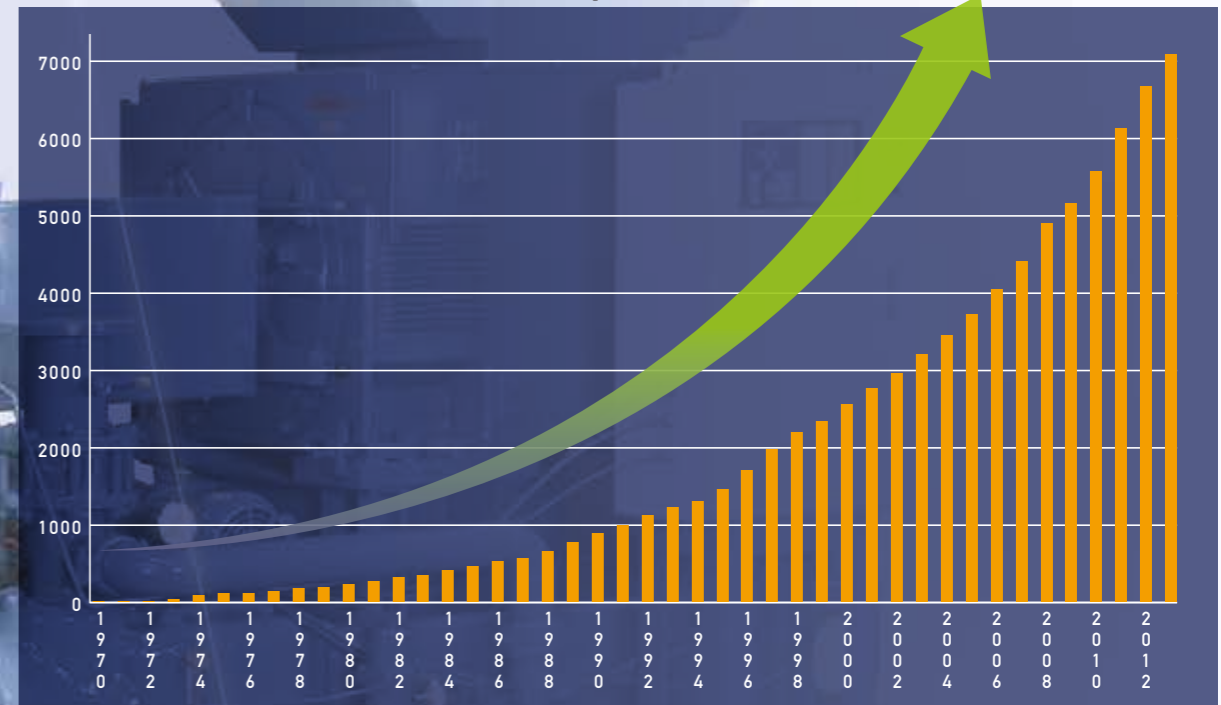

## 100% Oil-Free Air



IHI turbo compressors have passed the latest ISO8573-1 Class 0 oil free certification, which is the highest grade for compressed air's oil free quality, by an independent third-party test house TÜV in Germany.



## Easy Maintenance

IHI turbo compressors have a simple and robust design, in order to reduce maintenance costs. We have worked hard to simplify day to day maintenance procedures so that our products can provide a stable supply of compressed air throughout the year, with minimal maintenance.

# IHI Turbo Features

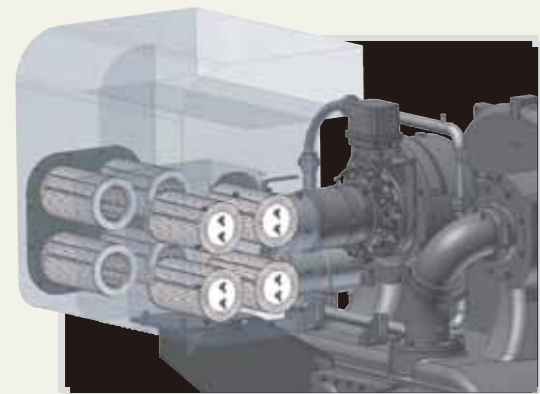

## Suction Filter

The suction filter uses a cartridge type element, making it very easy to maintain.

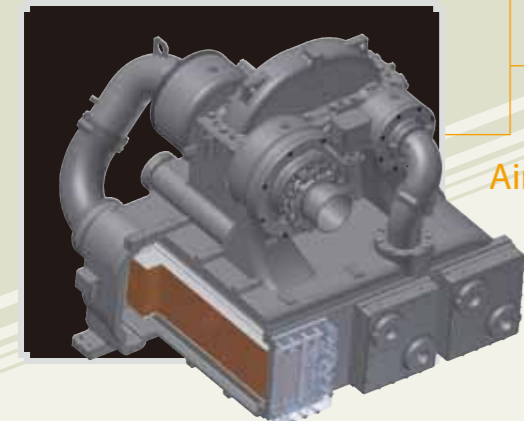
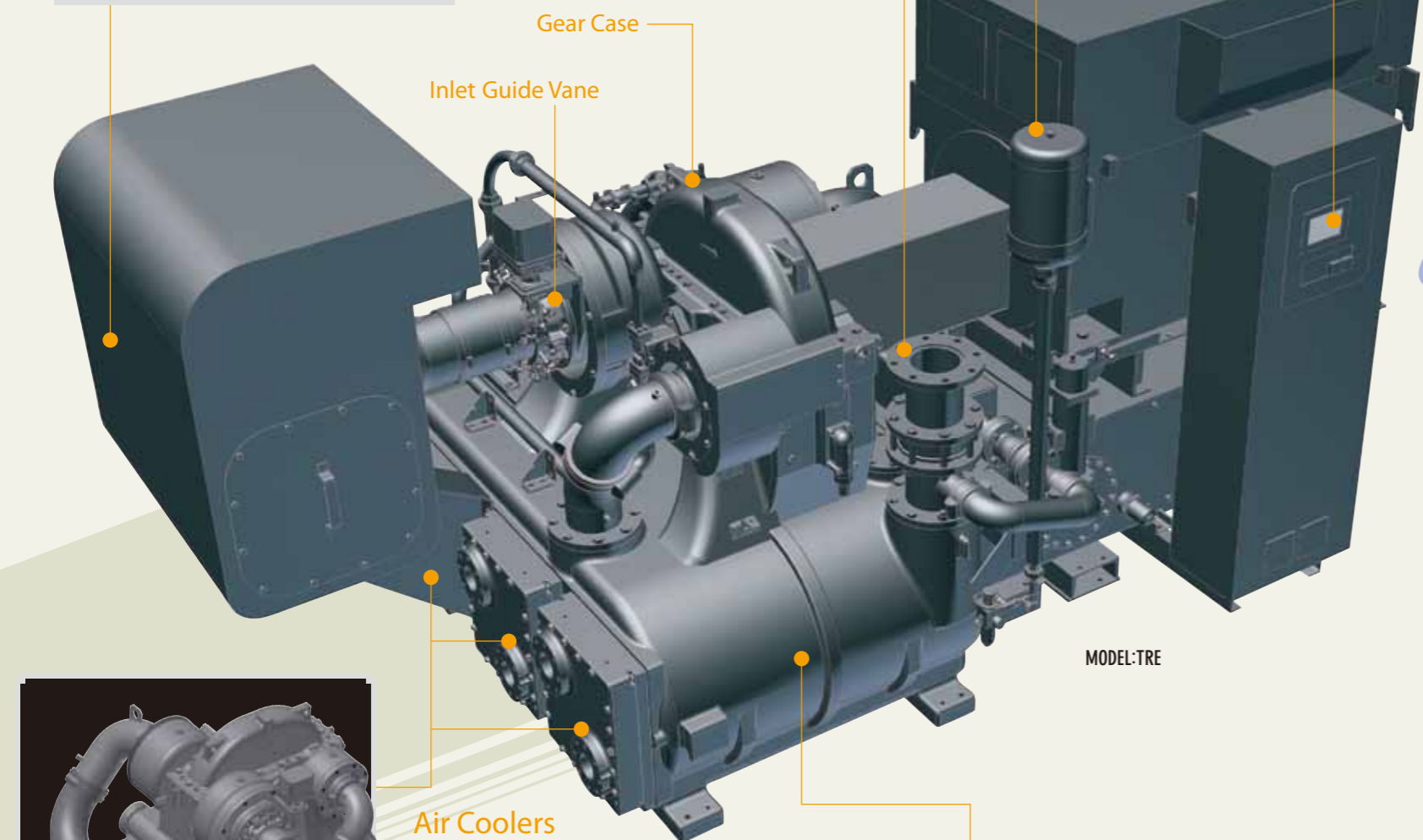

## Air Coolers

## Compressor Frame (one-piece gear case and air coolers)

The gear case and air coolers are cast together in a single, robust and compact construction. The compressor unit and air paths are surrounded by a thick, seamless wall that is also highly effective in cutting noise.

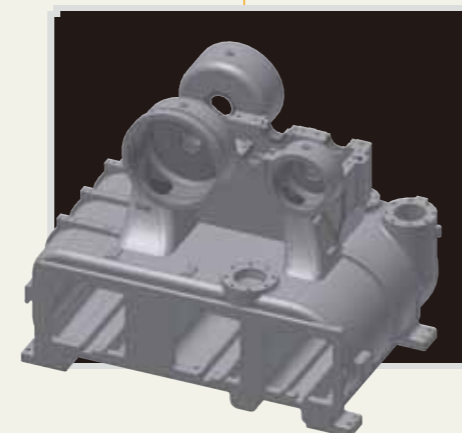

## [New] Microprocessor Control Panel

\*Except for Tx-M Model

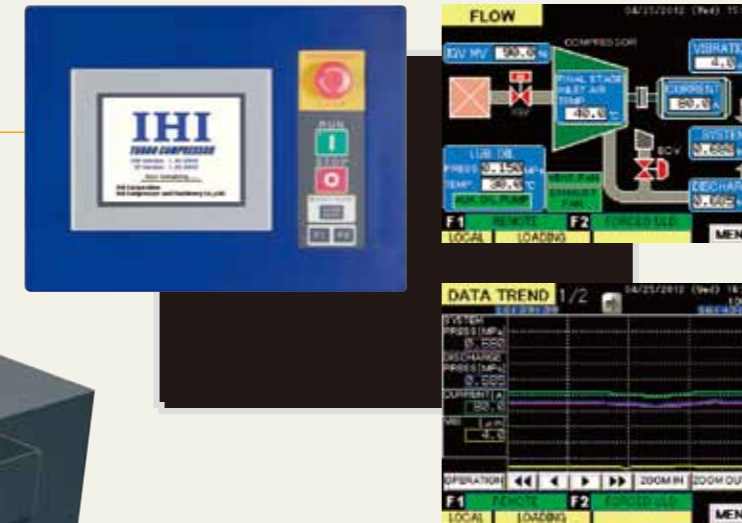

## Operating Conditions

For ease of daily monitoring, key measurements, data and operating conditions can be checked via the control panel's easy-to-read graphics.

## Trend Graph

The control panel provides a graphical interface that allows operators monitor key trends (discharge air pressure, motor current and shaft vibration), helping them to keep on top of operational conditions and plan maintenance routines.

## Recall Data

Measurement data can be recorded in the memory for each of the last five of both serious and minor shutdowns, along with the time of shutdown, and can be used for the rapid investigation of the shutdown cause.

## Causes & Countermeasures

In the event of a failure, causes and possible countermeasures can be checked onscreen, providing operators with clear guidance.

## Data Communication

It makes easier to check the operation condition by support of MODBUS® RTU.

※MODBUS® is registered trademark of Schneider Automation Inc.

## How turbo compressors work

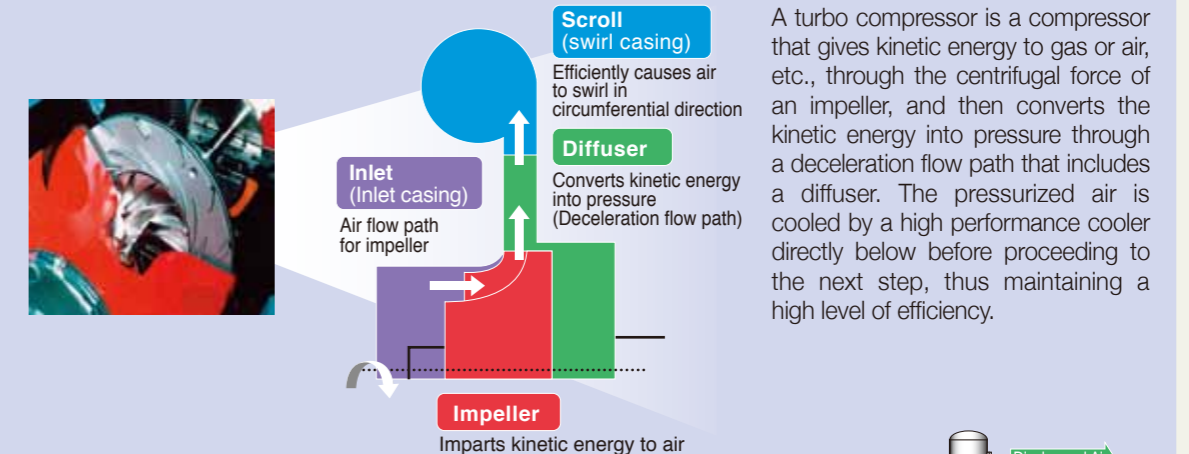

A turbo compressor is a compressor that gives kinetic energy to gas or air, etc., through the centrifugal force of an impeller, and then converts the kinetic energy into pressure through a deceleration flow path that includes a diffuser. The pressurized air is cooled by a high performance cooler directly below before proceeding to the next step, thus maintaining a high level of efficiency.

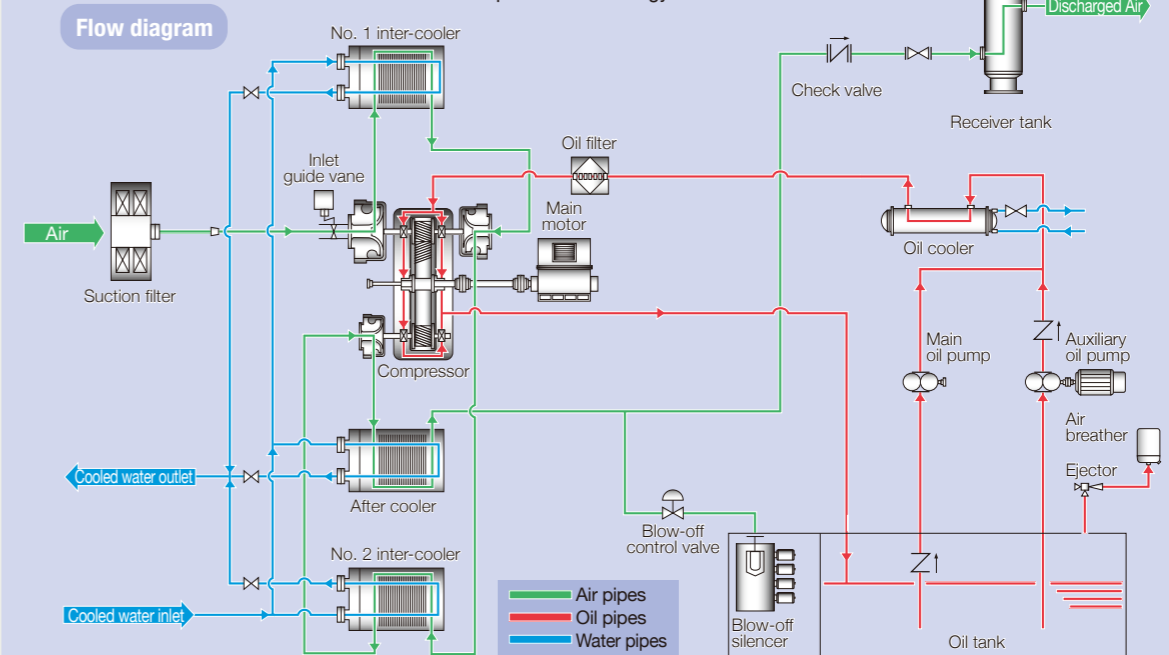

# Simple & Reliable

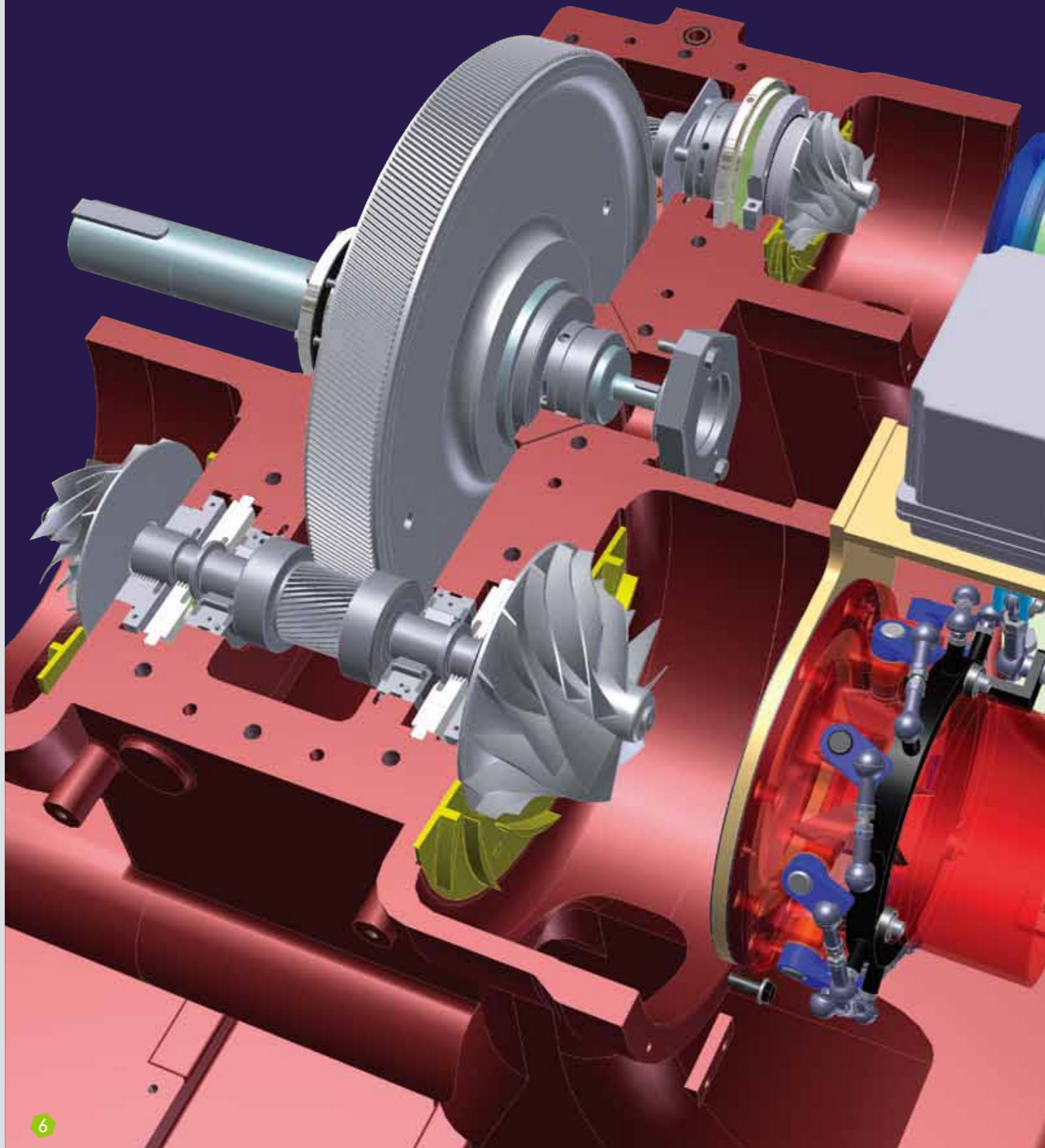

## Inlet guide vane (IGV)

With the inlet guide vane (inlet throttle valve), air supply can be controlled in accordance with consumption. Further, the inlet guide vane enhances efficiency by providing preswirl flow to the air taken into the compressor in the same rotative direction as the impeller.

\*Except for Tx-M Model

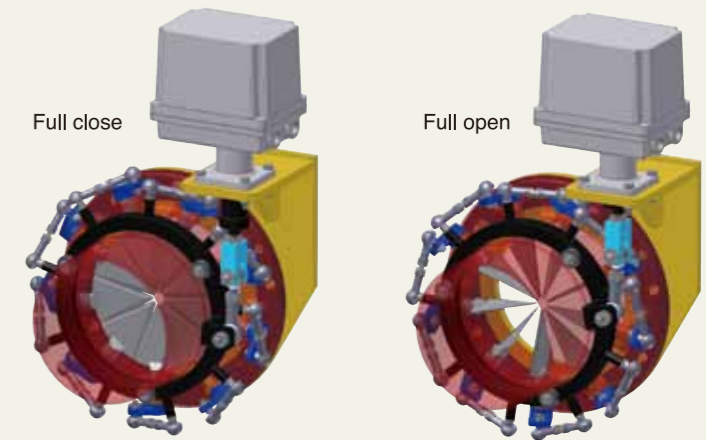

## Tilting pad journal bearing

Tilting pad journal bearings, which realize high-speed and stable operation, are adopted. Pad tilt will change in accordance with bearing load changes, which provides excellent compliance with load changes in the compressor.

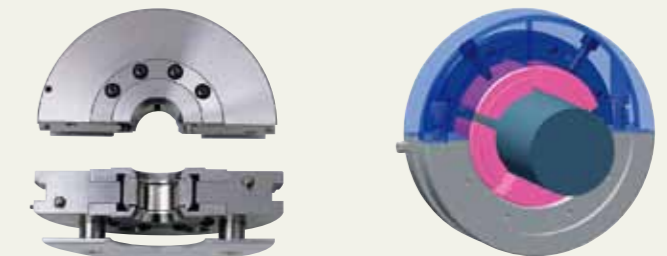

## Impeller

The three dimensional impeller, designed by making the fullest use of IHI's extensive experience and cutting edge CFD technology, enables world top class efficiency and a wide operating range. The use of both titanium and high strength stainless steel means there is no need to worry about wear or corrosion.



## Diffuser

The velocity energy imparted to air by the rotation of the impeller is efficiently converted into pressure energy by the diffuser. Because the impeller and diffuser are analysed together using cutting edge CFD technology, air turbulence is kept to an absolute minimum, and operating noise is extremely low.



## Labyrinth seal

For the air seal and oil seal, the labyrinth type, which has no contact with the shaft, is adopted, so there is no wear resulting from operation and no periodic replacement is required.

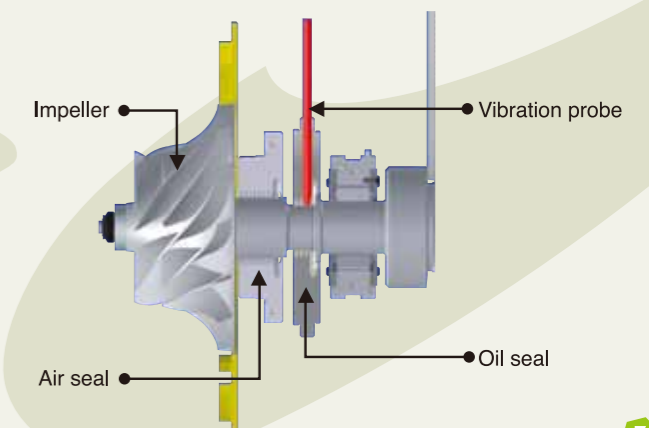

## 1 Constant pressure + Load/Unload control

A dual control system created by combining advantages of "constant-pressure control" and "load / unload control". Energy saving operation has been realized with efficient compressor control at each operation point.

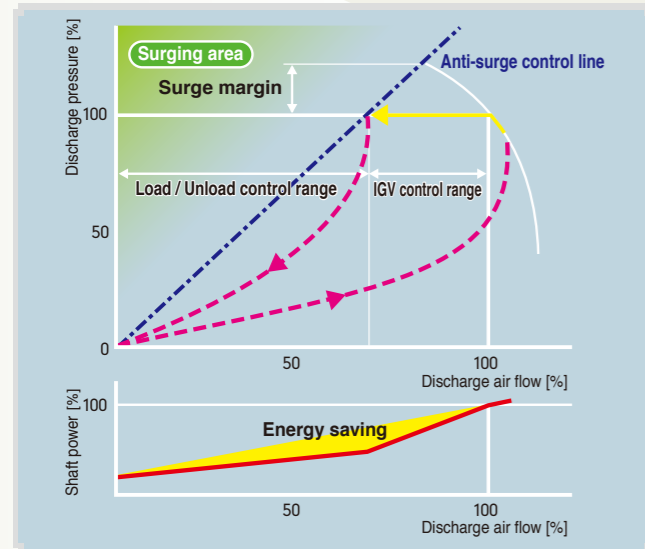

• **IGV control range (constant-pressure control range)**  
Discharge air flow is adjustable by IGV Opening/Closing. IGV is controlled to keep discharge line pressure constant.

• **Load / Unload control range**  
When consumption of air flow decreased, compressor turns into Unload operation automatically. And next, when discharge line pressure decreased, compressor comes back to Load operation automatically.

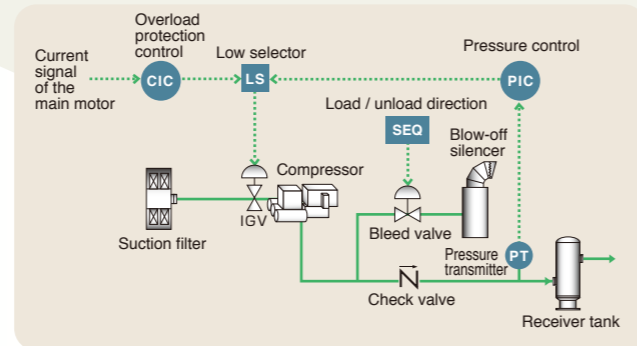

## 2 Constant pressure + Anti-surge control

Even if consumption of air would change between 0% to 100%, compressor keeps stable condition at a constant pressure.

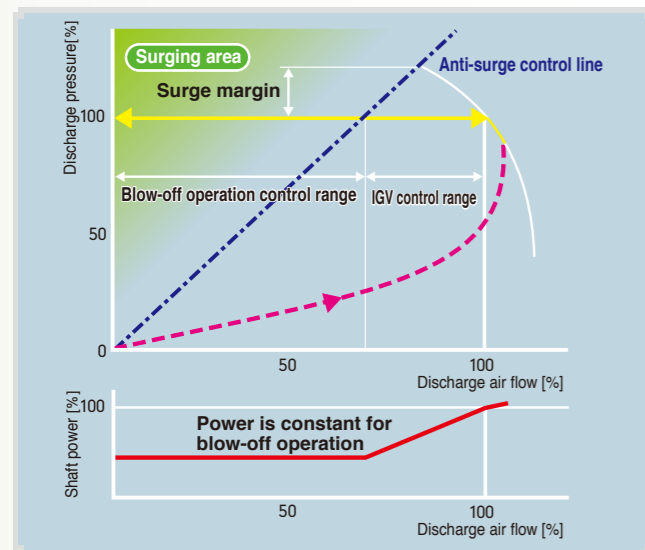

IGV is controlled according to an amount of plant air consumption. In this case, discharge pressure is kept constant and operation condition of compressor is kept stable too.

When air consumption become lower than the throttling range of IGV, discharge pressure is kept by controlling of blow off control valve.

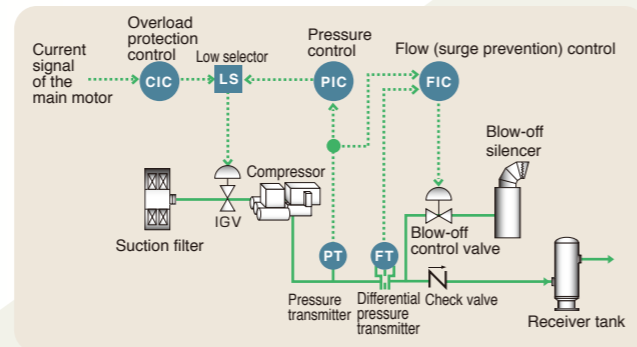

## 3 IGV synchronous capacity control (option)

In case of controlling the capacity of more than one compressor, IHI offers our IGV synchronous capacity control for multiple compressors.

This control realizes the wider constant pressure control range and decrease of unload time for Energy saving by combination of IGV constant pressure control and the Group control panel.

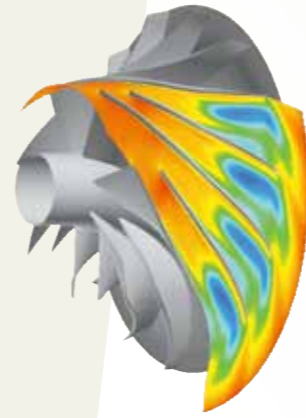
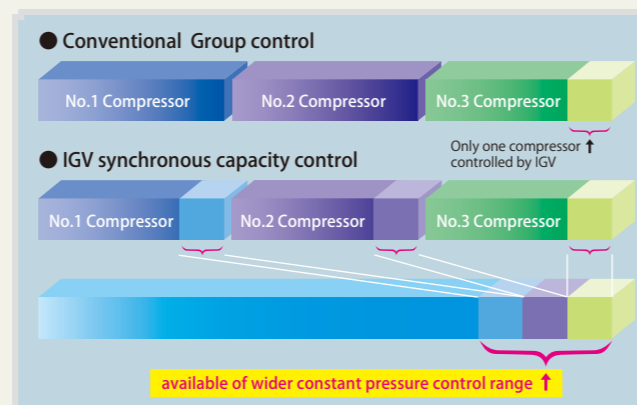

## Optimal impeller design

Optimal impeller design, matching the required airflow and pressure, contributes to energy saving.



## Various options

To meet the needs of individual customers, we offer a variety of options, such as enclosures and Group control panel, etc.

User Customization

Energy-saving

Easy Maintenance



## Impeller

The impeller is made from titanium and stainless steel, which are very resistant to corrosion and wear. Because there is no need for periodic replacement, maintenance costs can be kept low.



## Tilting pad journal bearing

Tilting pad journal bearings are used for the bearings of the high speed rotation impeller. Since this is a non-contact bearing, there is no wear, and the life of the part is semi-permanent.

※ Depending on the conditions of usage, the inner pad only may need to be replaced.

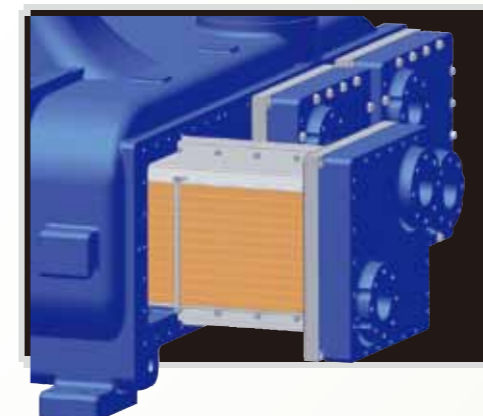

## Air coolers (inter coolers, after coolers)

To ensure the stable operation of the compressor, the coolers need to be cleaned periodically. The air coolers mounted on IHI turbo compressors are designed to allow water to flow along the pipes, and their construction makes cleaning very easy.

◀ Cooler fin and cooler tubes

# Energy-saving

## Base load machine selection

**1 Aggregation** Case where multiple small and medium sized compressors are used with little airflow fluctuation

● E.g. Four 170kW class oil-free compressors replaced with one TRE60-600kW compressor.

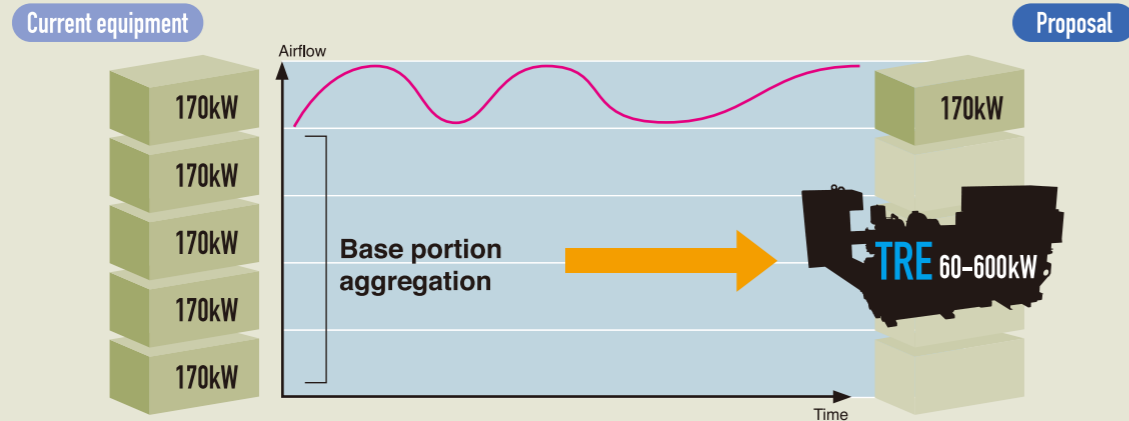

★Energy saving effect : approx. 18%  
★CO<sub>2</sub> reduction : 575 tons/ year

※Carbon dioxide emission coefficient : 0.000555tCO<sub>2</sub>/kWh

**2 Optimization** Case where a large compressor is used with large airflow fluctuation

● E.g. 600kW compressor operating at night at 45% load factor to be replaced with two TRA30-300kW compressors

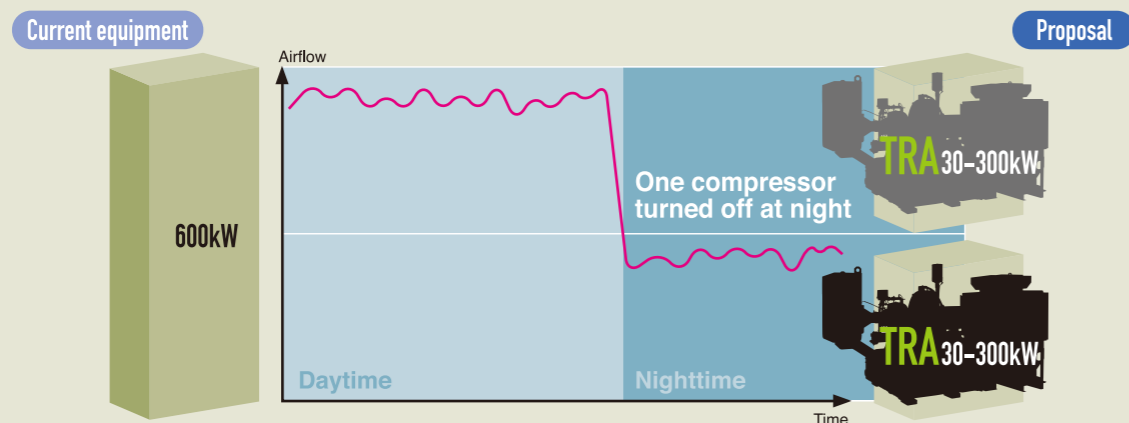

★ Nighttime energy saving effect : approx. 14%  
★ Nighttime CO<sub>2</sub> reduction : 107 tons/ year

※Carbon dioxide emission coefficient : 0.000555tCO<sub>2</sub>/kWh

Note : assuming average annual operating time of 8,000 hours

## Optimal pressure settings

IHI turbo compressors are available in a wide range of variations to match the plant air pressure.

Discharge pressure 0.69 MPaG (red curves in figure at right)

Discharge pressure 0.59 MPaG (green curves in figure at right)

### Case studies

**Case ① Spec** discharge pressure 0.69 MPaG compressor operated at discharge pressure 0.59 MPaG.

**Case ② Spec** discharge pressure 0.59 MPaG compressor operated at discharge pressure 0.59 MPaG.

Compared with case ①, case ② has an

airflow increase of approx. 3.5%.

When compared with the same shaft power, the

airflow increase is approx. 7%.

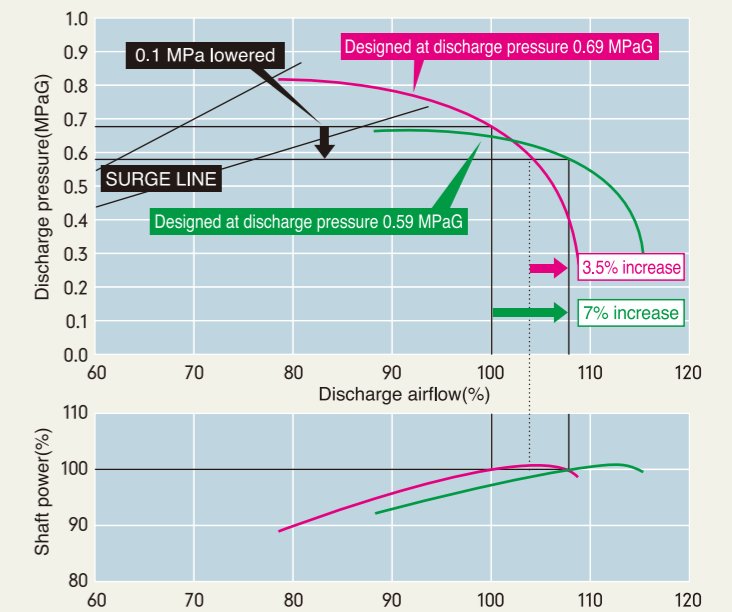

## Control system selection (IGV energy saving effect)

The compressor's inlet has vanes whose angles can be changed in order to reduce the impeller air intake. This is more effective than using a butterfly valve to add pressure loss in order to reduce airflow, and if the same airflow is discharged, the dynamic power can be kept low.

### Difference between IGV and butterfly valve drive power (example)

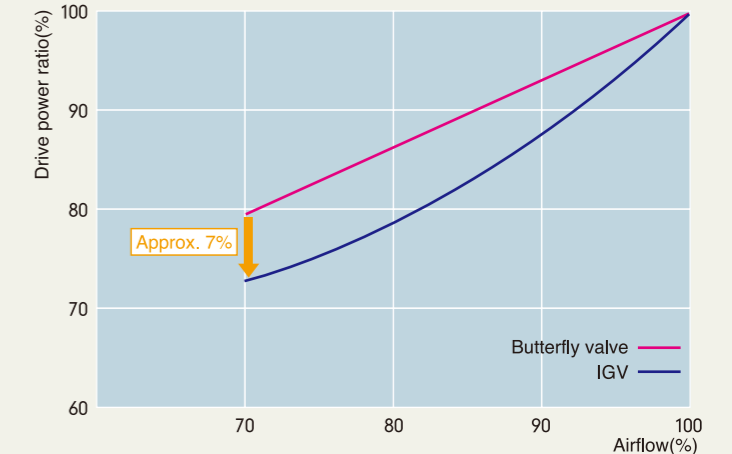

## Intake temperature selection

IHI turbo compressors are designed to operate under the severe/tough summer conditions of ambient temperature 35°C and relative humidity 80%. Lowering the temperature and humidity will improve the drive power ratio accordingly. Therefore, energy saving effect is also obtained by using an "external air intake", sucking in cool air from outside.

※The motor overload prevention function prevents air intake if the airflow exceeds the motor's maximum capacity.

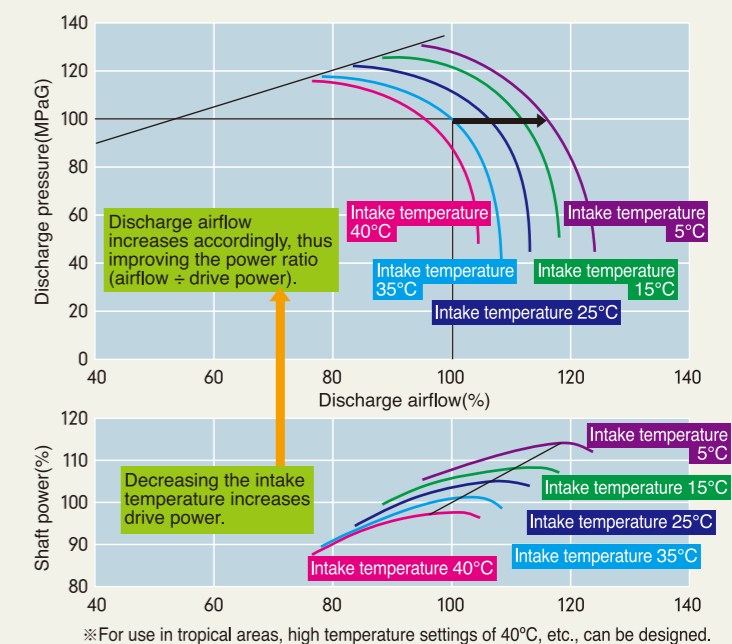
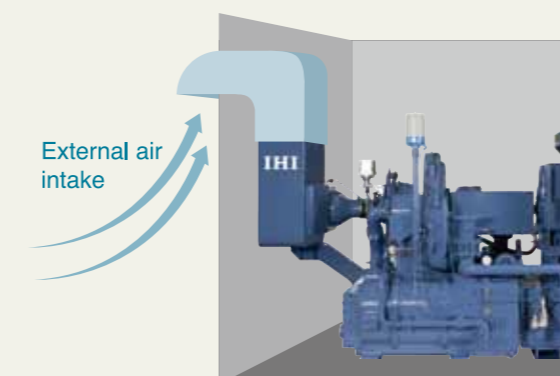

※For use in tropical areas, high temperature settings of 40°C, etc., can be designed.

# IHI Turbo Compressor Line-up



**Tx-M** Compression stages: 2 stages (Discharge Pressure: 0.69MPaG)

Model	Motor (kW)	Flow Rate (m <sup>3</sup> /h)	Dimensions (mm)			Weight (kg)
			Length	Width	Height	
Tx-M	75	785	2,200	1,300	1,400	2,200
	100	1,080	2,300	1,300	1,500	2,300

**T3** Compression stages: 3 stages (Discharge Pressure: 0.69MPaG)

Model	Motor (kW)	Flow Rate (m <sup>3</sup> /h)	Dimensions (mm)			Weight (kg)
			Length	Width	Height	
T3A 70	750	8,200	4,600	2,250	2,000	10,000
T3A 130	1,320	13,800	5,700	2,500	3,000	16,000

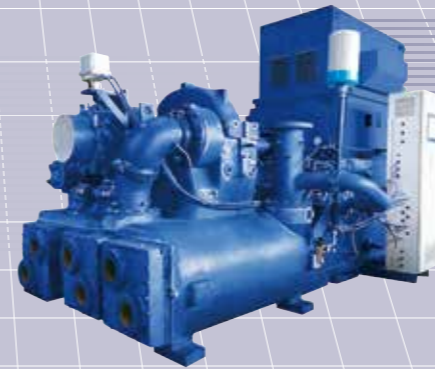

■ T3 Schematic

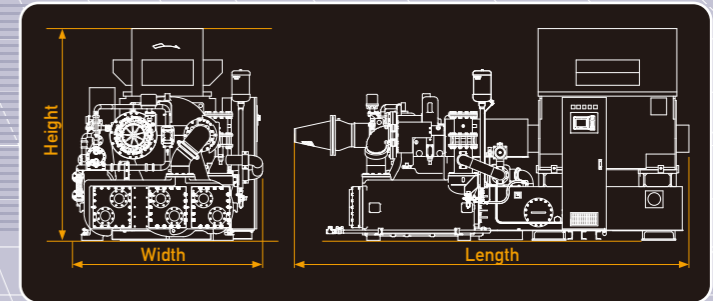

**T2** Compression stages: 2 stages (Discharge Pressure: 0.69MPaG)

Model	Motor (kW)	Flow Rate (m <sup>3</sup> /h)	Dimensions (mm)			Weight (kg)
			Length	Width	Height	
T2A	125	1,394	2,450	1,640	1,900	4,500
	230	2,648				

■ T2 Schematic

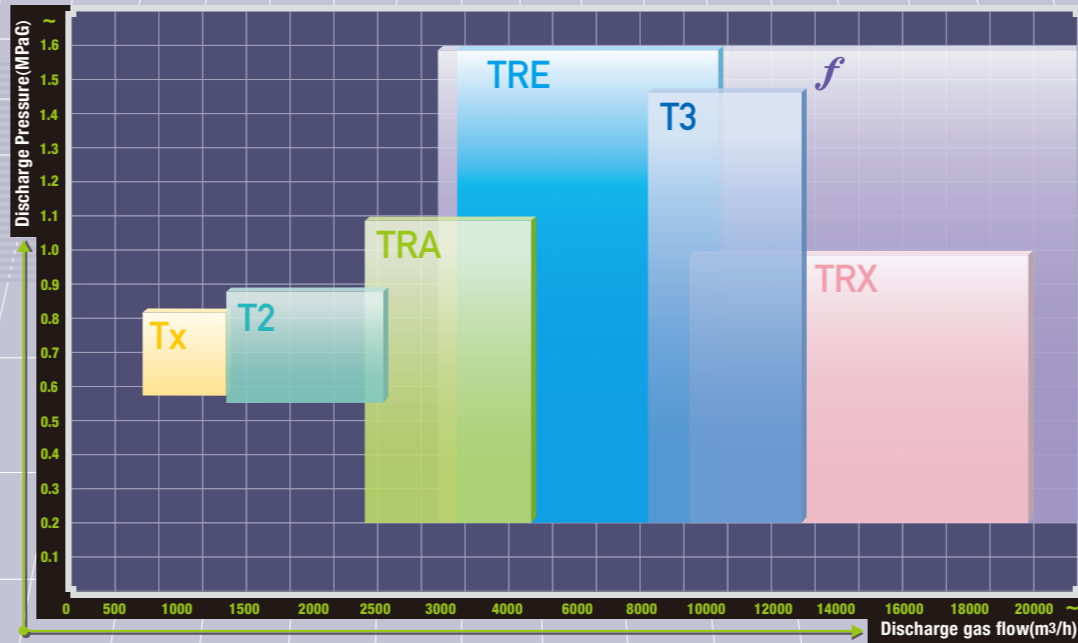
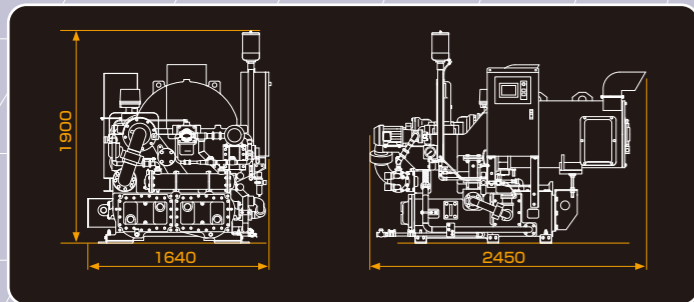

■ TRX Schematic

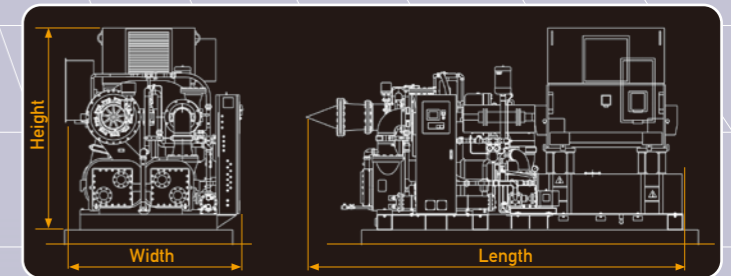

■ TRE Schematic

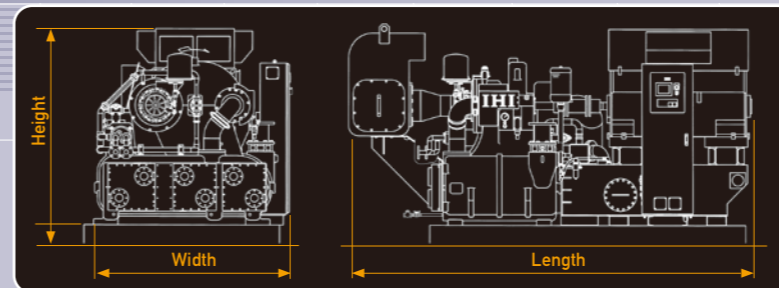

**TRA** Compression stages: 3 stages (Discharge Pressure: 0.69MPaG)

Model	Motor (kW)	Flow Rate (m <sup>3</sup> /h)	Dimensions (mm)			Weight (kg)
			Length	Width	Height	
TRA 20	250	2,470	3,700	2,000	2,000	7,100
TRA 40	450	4,940	4,000	2,000	2,200	8,500



■ TRA Schematic

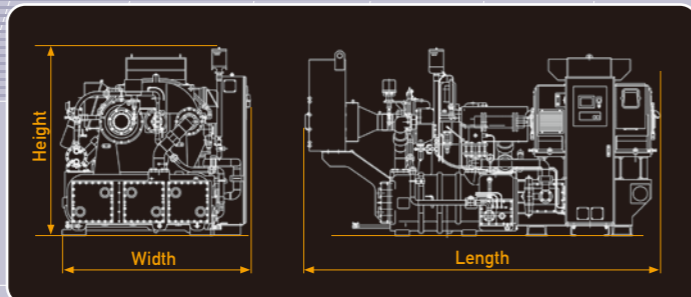

**TRE** Compression stages: 3 stages (Discharge Pressure: 0.69MPaG)

Model	Motor (kW)	Flow Rate (m <sup>3</sup> /h)	Dimensions (mm)			Weight (kg)
			Length	Width	Height	
TRE 30	375	3,600	4,100	1,950	2,000	8,300
TRE 90E	950	10,550	5,200	2,300	2,800	13,500

**TRX** Compression stages: 3 stages (Discharge Pressure: 0.69MPaG)

Model	Motor (kW)	Flow Rate (m <sup>3</sup> /h)	Dimensions (mm)			Weight (kg)
			Length	Width	Height	
TRX 90	900	9,500	4,800	2,100	2,150	13,500
TRX 180	1,800	20,000	6,000	2,300	3,300	20,000

NOTES

- The above tables display flow rate ranges at typical discharge pressures.
- Flow rate (m<sup>3</sup>/h) is converted to compressor suction conditions as indicated below.
- Reference conditions:
  - Atmospheric pressure: 0.1013MPa(abs.)
  - Suction pressure: 0.0993MPa(abs.)
  - Suction temperature: 35°C
  - Relative humidity: 80%
  - Cooling water inlet temperature: 32°C
- Flow rate is measured at inlet point.

**f series** Compression stages: 3 stages (Discharge Pressure: 0.69MPaG)

Model	Motor (kW)	Flow Rate (m <sup>3</sup> /h)	Dimensions (mm)			Weight (kg)
			Length	Width	Height	
f 25	350	3,000	6,100	2,300	2,800	10,000
f 36	1,700	18,500	9,100	3,100	3,700	26,500

※ The f series can handle even larger capacity types.



